



ASSEMBLY INSTRUCTION

SHADE MASTER MK2 IMPERIAL CANTILEVER UMBRELLA

ITEM CODE - 72490

Imported by Amart Furniture Pty Ltd, Qld, Brisbane Australia .
For any assistance with assembly or for missing parts please phone
Amart Furniture , Customer Service Freecall 1800 351 084

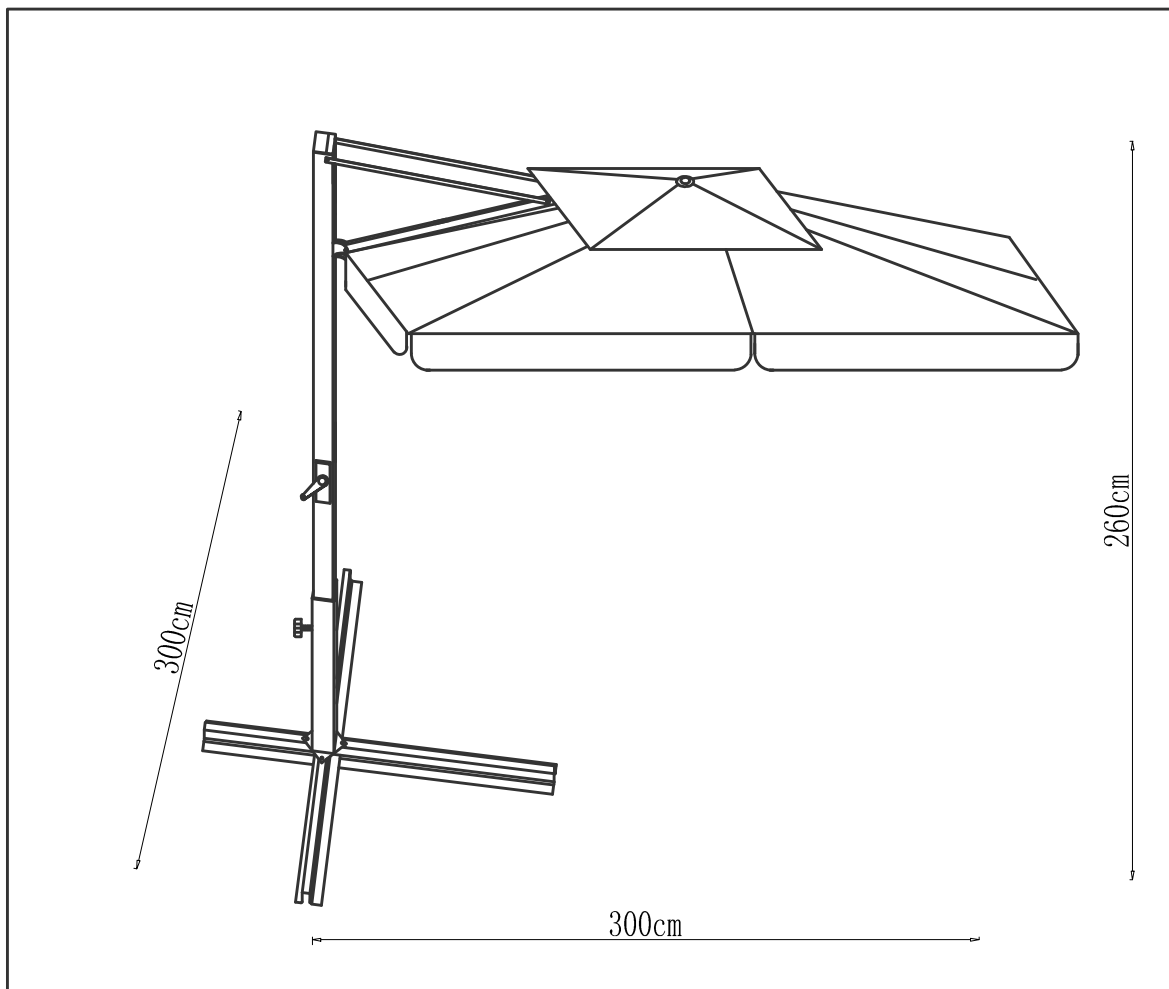

Imported by Amart Furniture Pty Ltd, Qld, Brisbane Australia .
For any assistance with assembly or for missing parts please phone
Amart Furniture, Customer Service Freecall 1800 351 084

PRE-ASSEMBLY PREPARATION



Before you start:

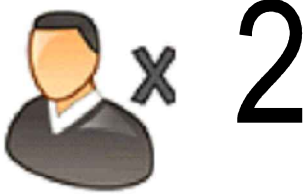

1. Choose a clean, level, spacious assembly area. Avoid hard surfaces that may damage the product.
2. Take care when lifting. Product should be assembled as near as possible to the point of use.
3. Ensure that you have all required contents for complete assembly.
4. Always read the assembly instructions carefully before beginning assembly.
5. Keep all hardware parts and packaging out of reach of small children.
6. Do not over tighten the screws and bolts as this may damage the threads.

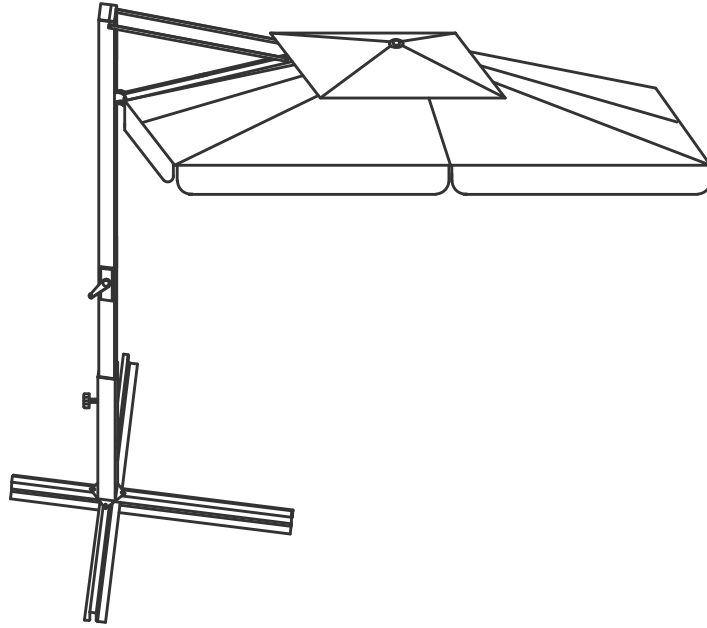
	
ALLOW 20 MINUTES	PEOPLE REQUIRED
ADDITIONAL TOOLS REQUIRED	

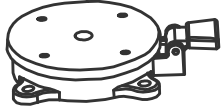
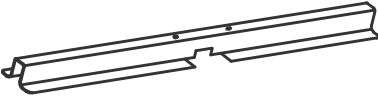
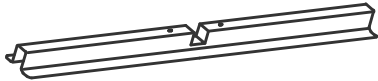
PARTS LIST

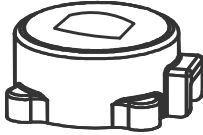

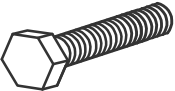

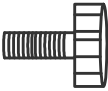
<p>1 Umbrella Frame 1PC</p> 	<p>2 Rotating Disk 1PC</p> 
<p>3 Top Cross Bar 1PC</p> 	<p>4 Bottom Cross Bar 1PC</p> 
<p>5 Bottom Pole 1PC</p> 	<p>6 Fixed disk 1PC</p> 

<p>A. Bolt 8PCS</p> 	<p>B. Shim 8PCS</p> 	<p>C. Wrench 1PC</p> 	<p>D. Adjust Knob 1PC</p> 
---	---	---	---

Step 1:

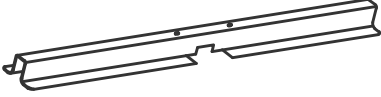
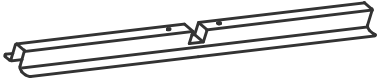
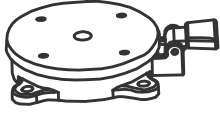
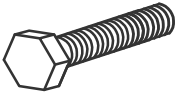
ITEMS REQUIRED

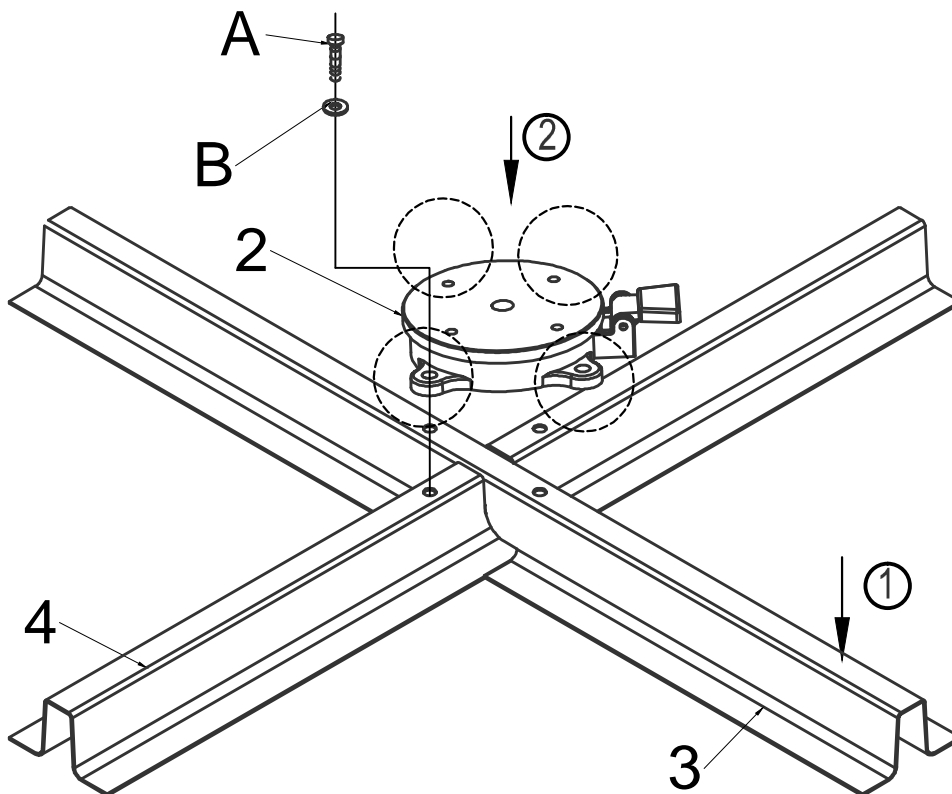

3. Top Cross Bar 1PC 	4. Bottom Cross Bar 1PC 	2. Rotating Disk 1PC 
A. Bolt 4PCS 	B. Shim 4PCS 	C. Wrench 1PCS 

- Attach top cross bar (3) to bottom cross bar (4) using rotating disk (2) and bolt (A) with shim (B).
- Tighten with wrench (C) .

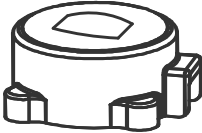
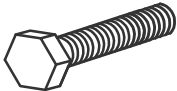

Step 2:

ITEMS REQUIRED

5.	Bottom Pole	1PC	6.	Fixed disk	1PC			
								
A.	Bolt	4PCS	B.	Shim	4PCS	C.	Wrench	1PCS
								

- Attach bottom pole (5) and (6) to step 1 using bolt (A) with shim (B).
- Insert all bolts before fully tightening .
- Tighten with wrench (C) .

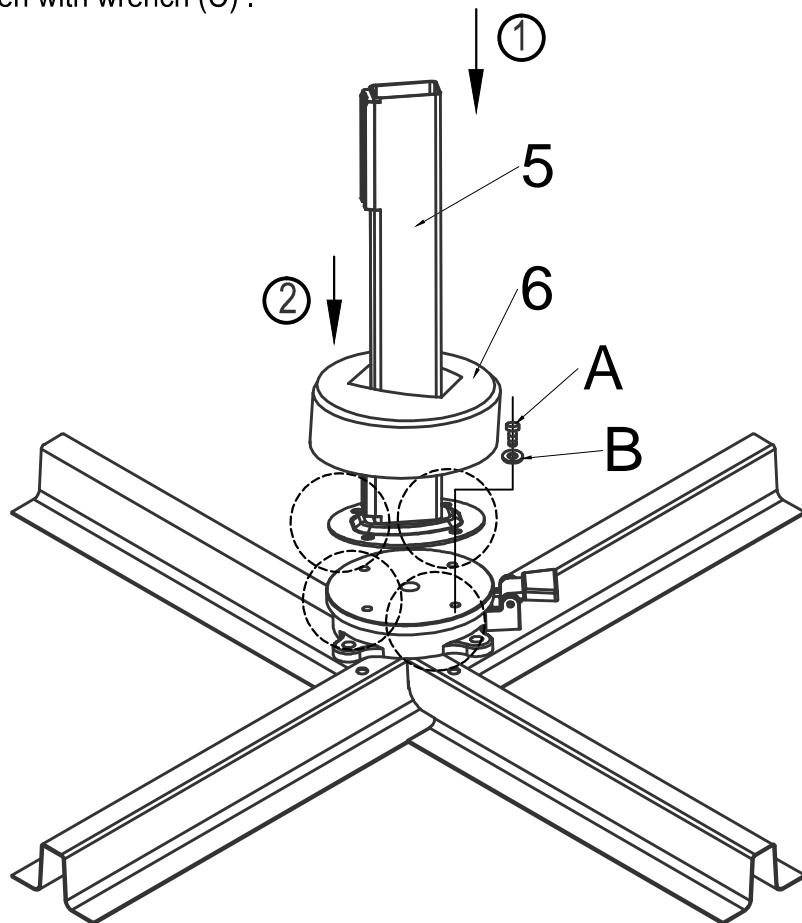

Step 3:

ITEMS REQUIRED

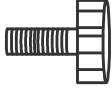
1. Umbrella Frame 1PC	D. Adjust Knob 1PC
	

- Attach umbrella frame (1) to step 2 using bolt (A) with adjust knob (D).

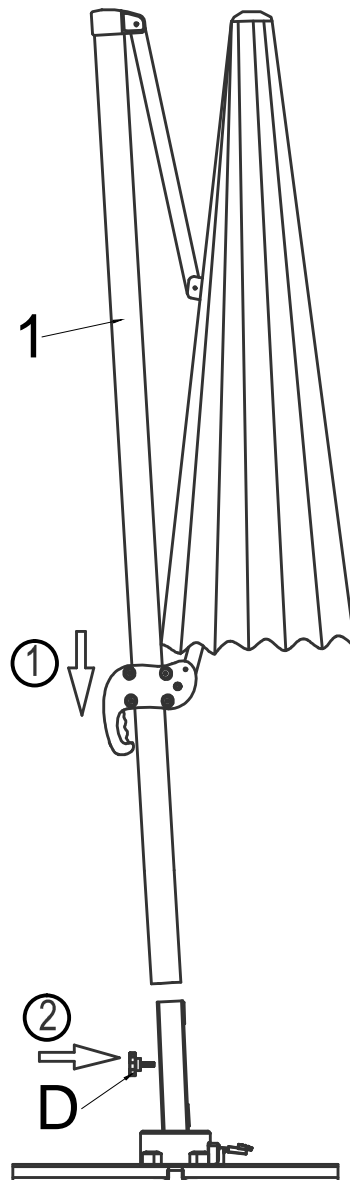

Step 4:

ITEMS REQUIRED

- Please make sure umbrella bases or weights are placed before you open it.
- Hold the lever on the handle down the slide handle up.

Warning:

Umbrellas are to be used in conjunction with weights.

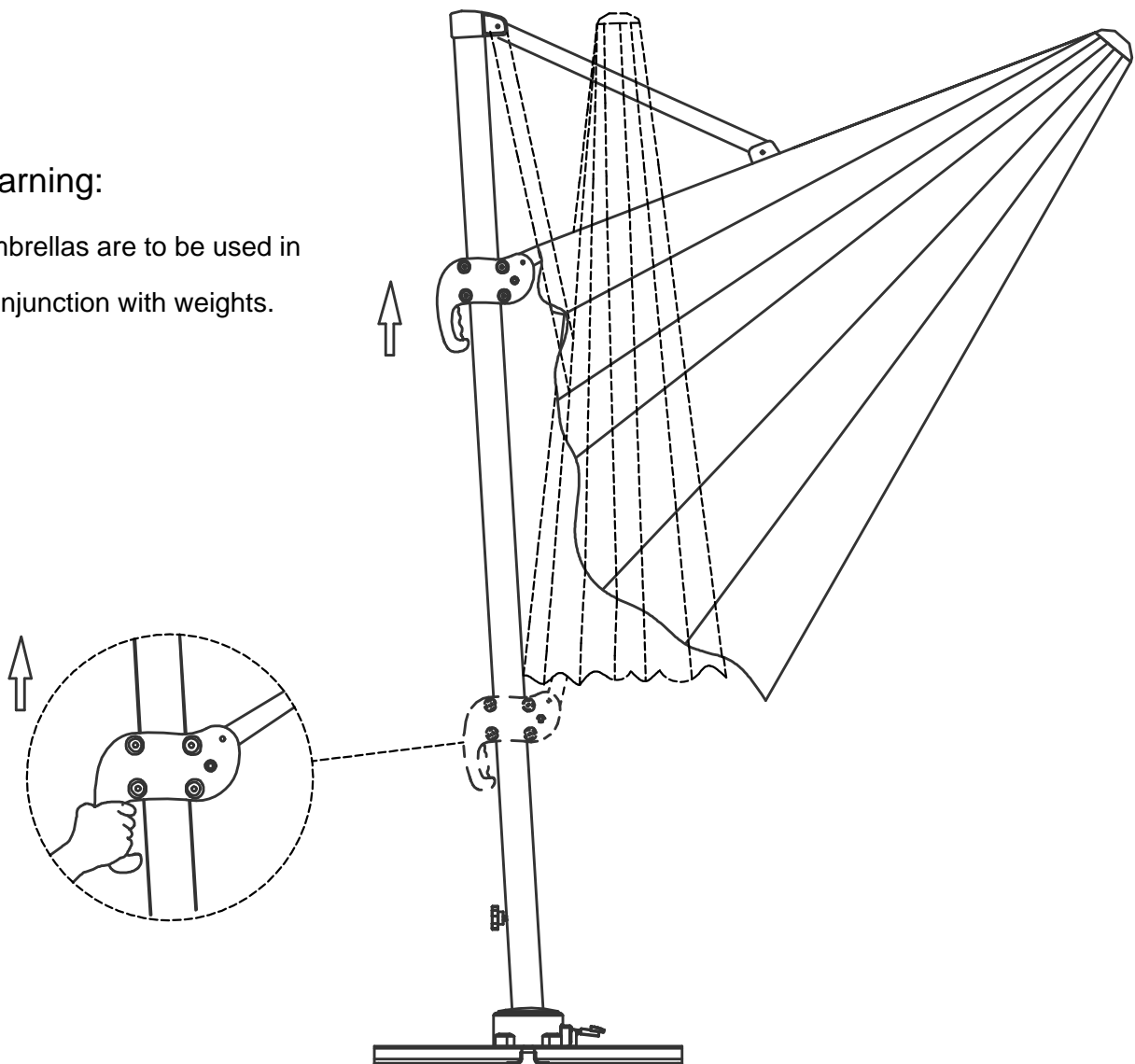

Step 5:

ITEMS REQUIRED

- Turn the crank handle in clockwise direction to open the umbrella.
- Please Do not over turn the crank that may damage the crank working mechanism.

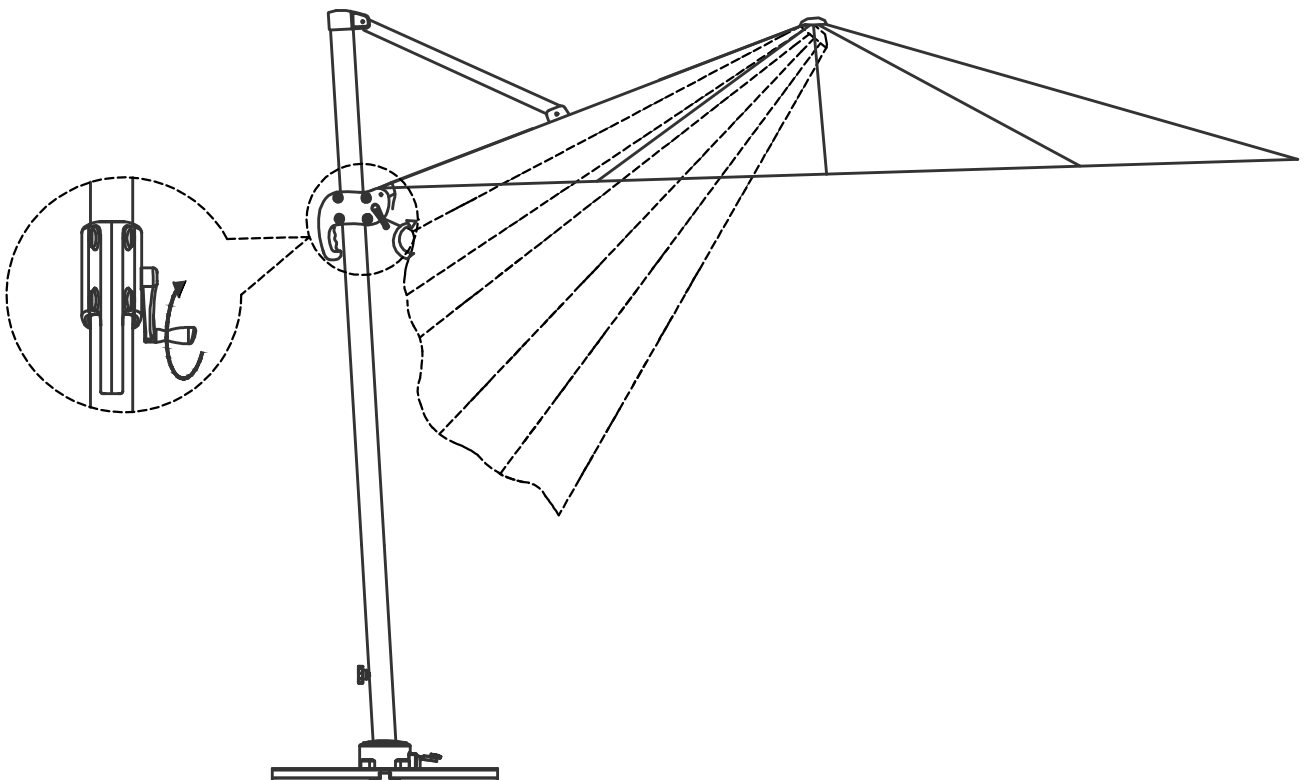

Step 6:

ITEMS REQUIRED

- Holding the handle can control the direction of the umbrella.

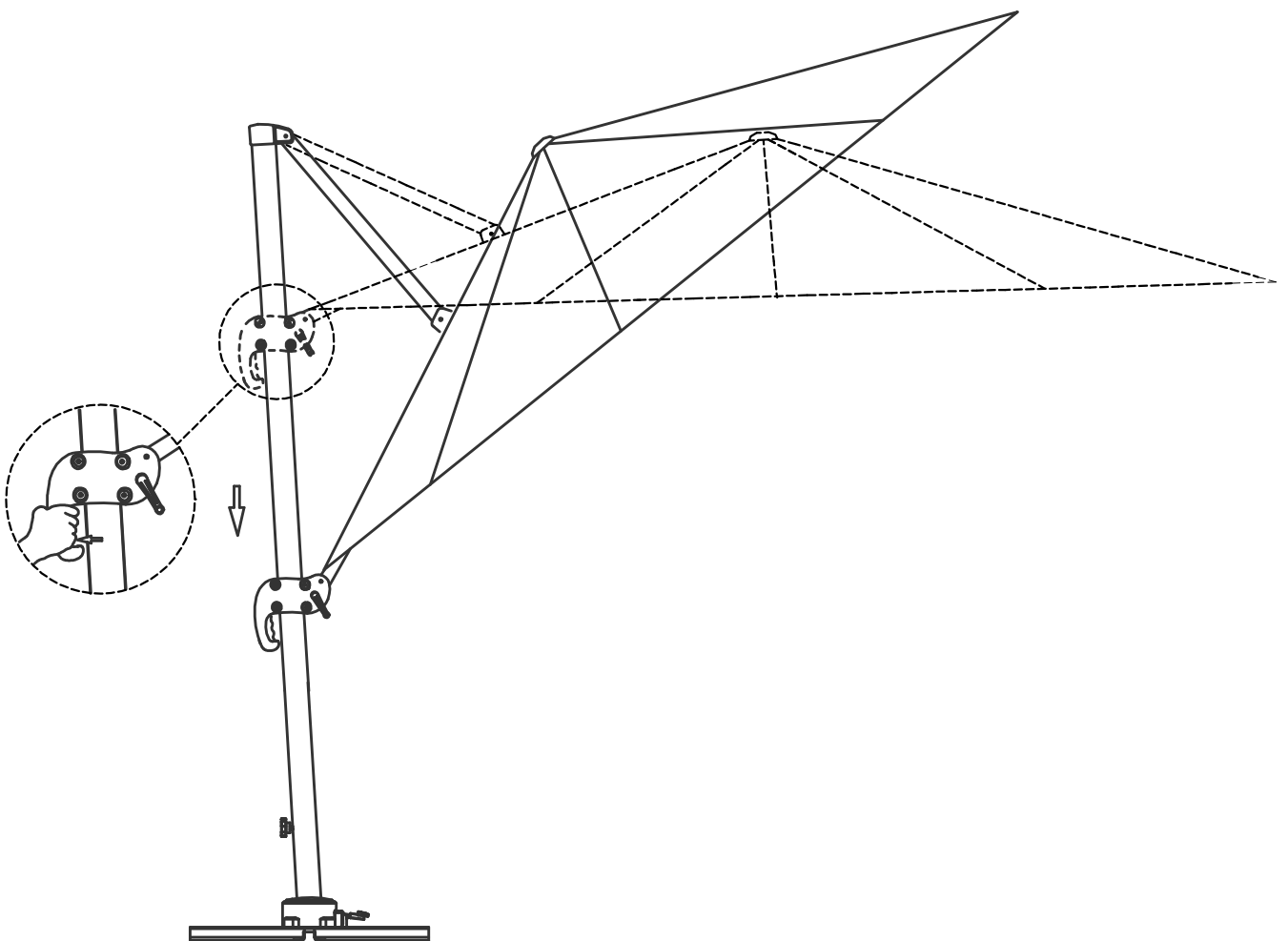

Step 7:

ITEMS REQUIRED

- Pressing the rotary rotating disk will enable you to rotate the umbrella.

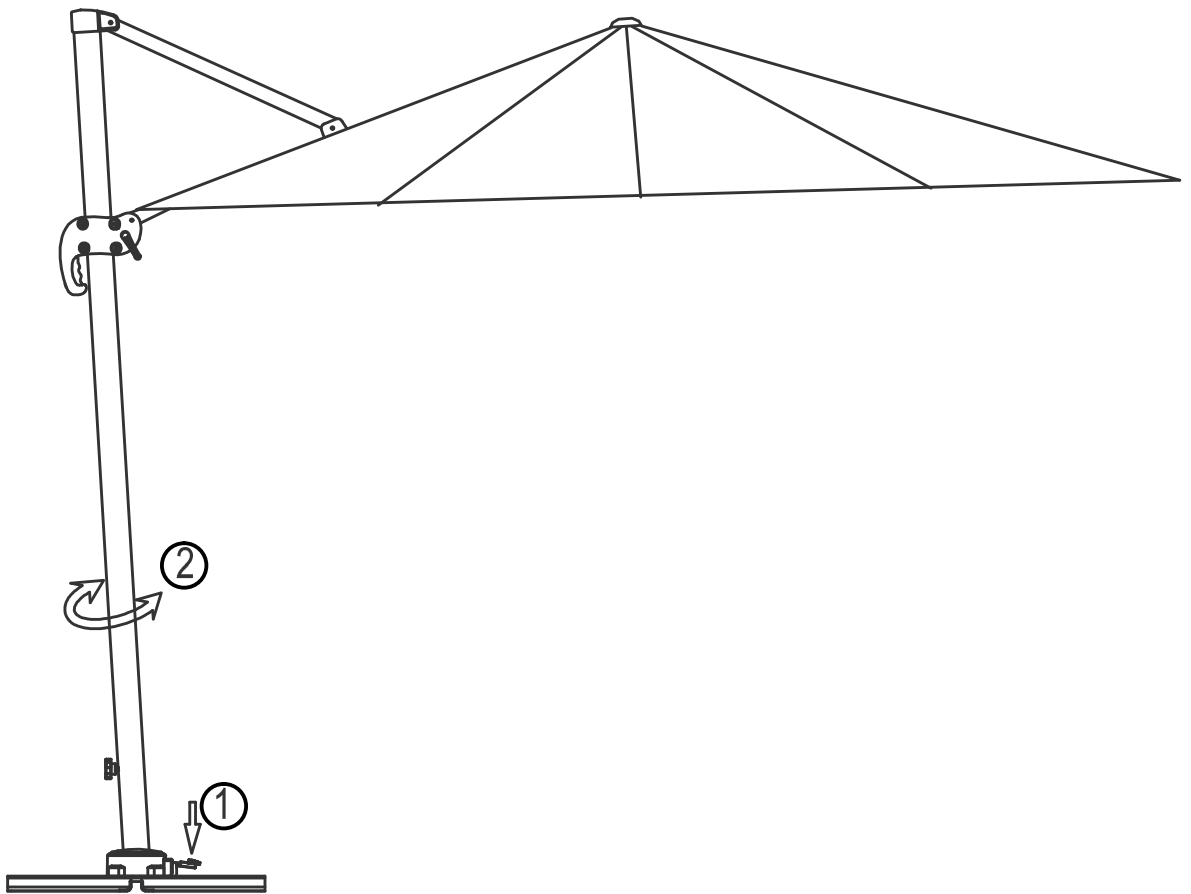

Step 8:

ITEMS REQUIRED

- Turn the crank handle in counter clockwise direction to close the umbrella.

CLOSE

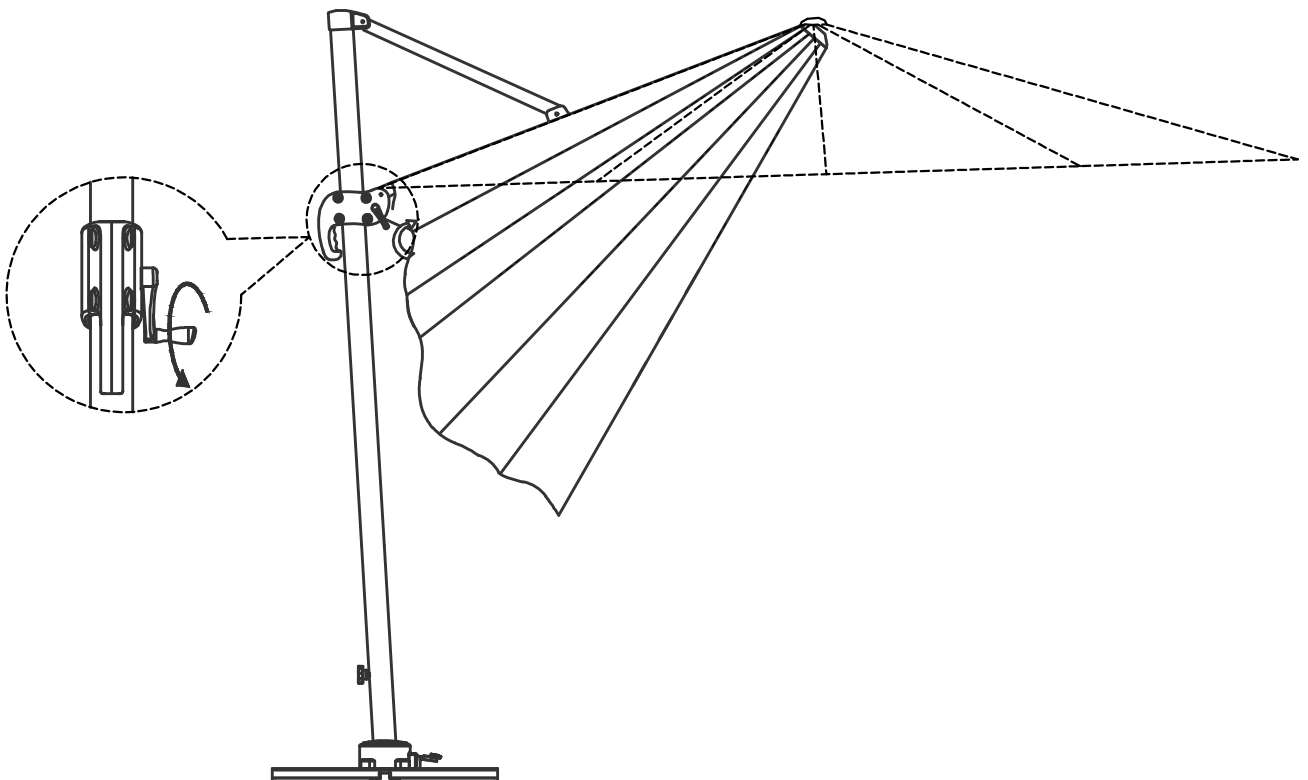

Step 9:

ITEMS REQUIRED

- Hold lever down on the handle and slide handle down to close umbrella.

CLOSE

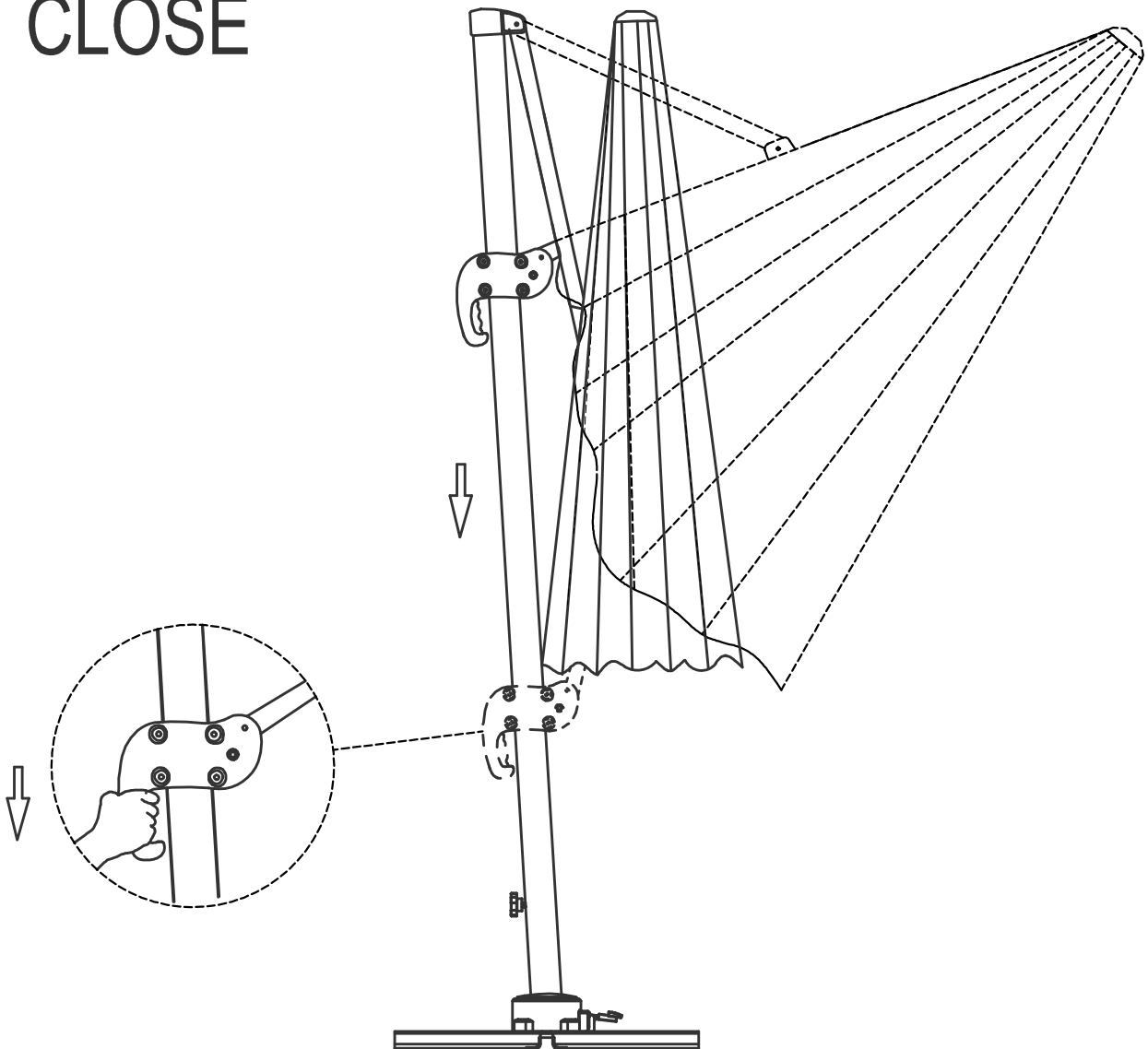

ASSEMBLY IS COMPLETE

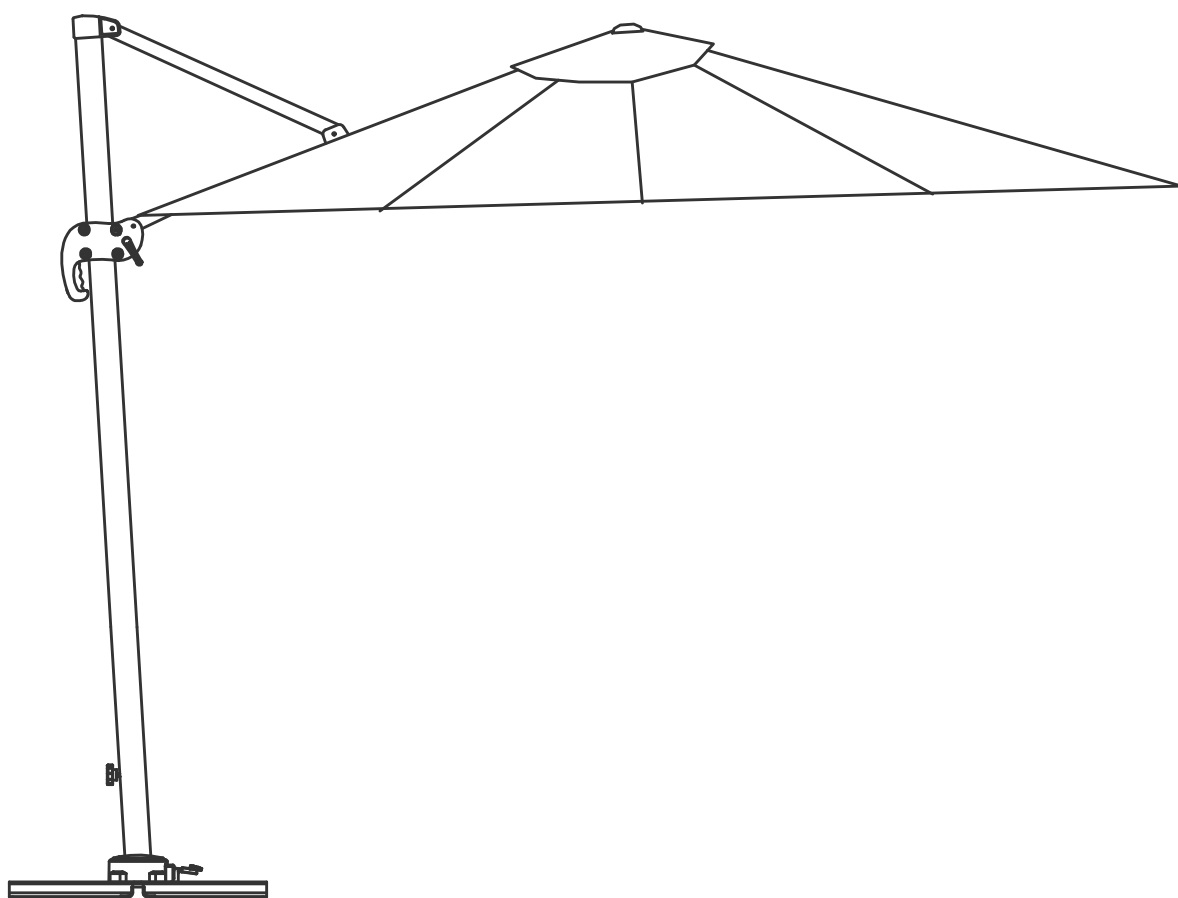

Care and maintenance



Safety:

- **Umbrellas are not permanent shade structure.**
- **Completely close and store in a dry place when not in use.**
- **Using this umbrella in strong winds can cause damage to the Umbrella, property and may also be a danger to people.**
- **Domestic free standing umbrellas are not recommended for exposed environments such as high balconies or roof tops.**

Wind:

- Excessive wind puts great stress on the frame, so please fully collapse this Umbrella in high wind conditions and when not in use.

Fabric:

- Do not store when wet as mould can occur.
- Do not allow sunscreen, sun tan oil or insect repellent to come into contact with the fabric as staining may occur.
- Avoid placing the Umbrella in areas where trees and plants can drip sap onto the fabric.

Cleaning:

- Spills and dirt should be removed immediately to avoid staining.
- Blot spills with a clean, dry cloth and avoid rubbing.
- Dust can be removed simply vacuuming or brushing with a soft brush.
- Spot wash individual dirt/stains with lukewarm mild soapy water with a soft bristled brush.
- Be sure to rinse thoroughly with fresh water and leave umbrella open to fully dry.
- Do not clean in direct sunlight.
- Do not use harsh cleaning products or pine oil cleaners.
- For persistent stains, consult a professional cleaner.

Frame/Base:

- Wipe clean with a soft cloth or soft bristled brush.
- For dirt/grime, use a mild soapy water with soft cloth.

Storage:

- When not in use, close the umbrella and store in a dry place.
- Use an umbrella cover where possible.